

Synchronous Motor

SSM-25IHP

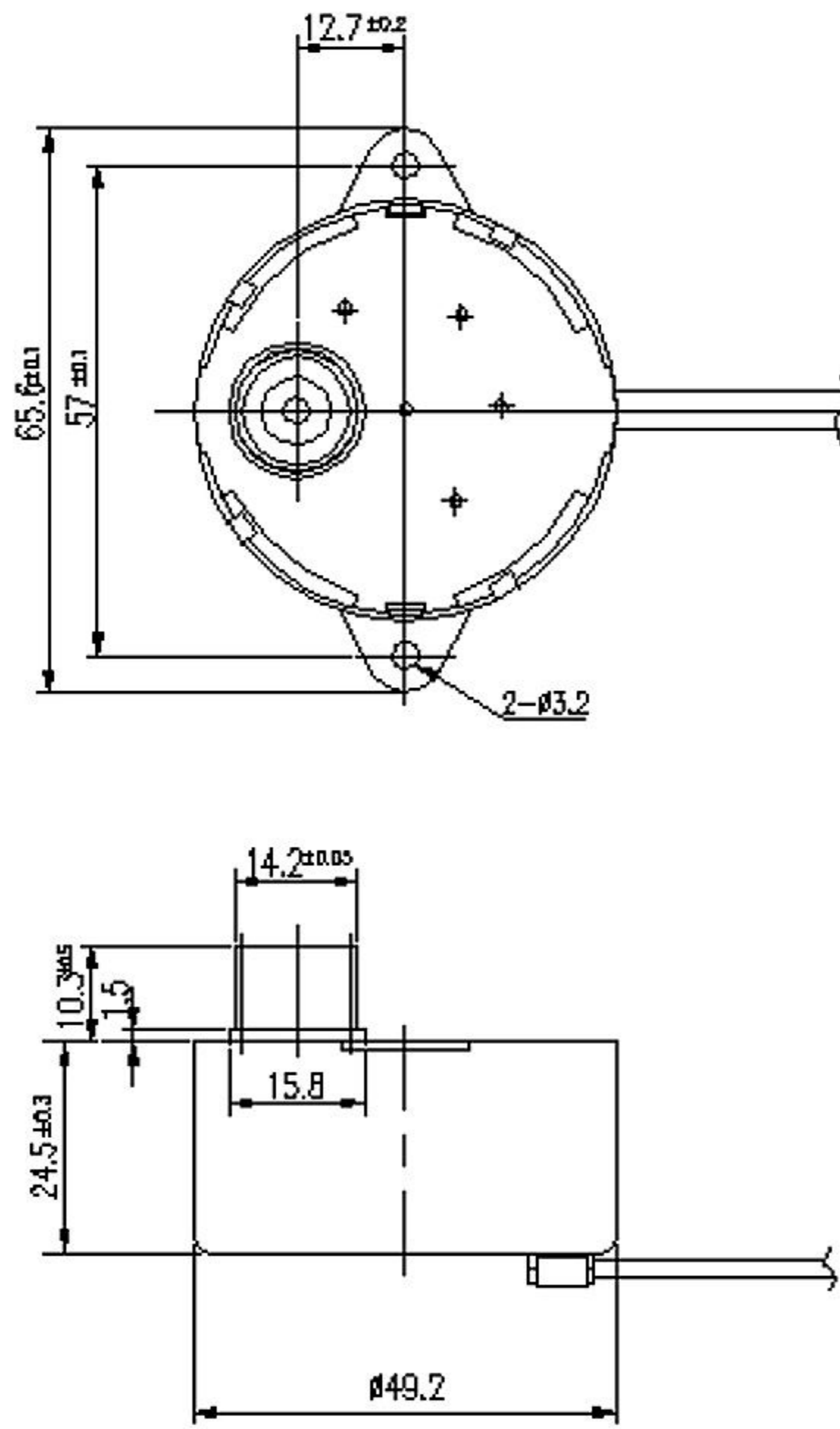

DIMENSION



SPECIFICATION

ITEM	SPECIFICATION							
RATED VOLTAGE	AC24, 100, 120, 220/240V							
FREQUENCY	50, 60, 50/60Hz							
STANDARD SPEED	50Hz	5	7.5	18	10.2	18	45	150
	60Hz	6	9	22	12.2	22	54	180
STALLING TORQUE	8.0 6.0 4.0 2.0 1.0 0.2 kgf-Cm Min							
INPUT POWER	3.0 4.0W MAX							
TERMINAL SHAPE	LEAD WIRE TYPE							
MATERIAL OF SHAFT	METAL TYPE							
APPLICATION	FAN, COPY MACHINE, LAMINATOR Etc							