

# SPEED CONTROLLER REVERSIBLE MOTOR 6W □60mm LEAD WIRE TYPE



제품사진





# 6W

REVERSIBLE SPEED CONTROL MOTOR  
 60mm LEAD WIRE TYPE

## SPECIFICATION OF SR TYPE SPEED CONTROL MOTORS

SIZE mm sq.	Motor Type	Controller Type	Poles	Output (W)	Voltage (V)	Freq. (Hz)	Duty	Speed Range (rpm)	Permissible Torque				Starting Torque		Cap. ( $\mu$ F)
									at 1200rpm		at 90rpm		(kg-cm)	(N-m)	
60	S6R06GA-S12 S6R06GA-S12CE	SRA01 SRA01CE	4	6	1 $\phi$ 110	60	30min.	90-1700	0.65	0.065	0.40	0.040	0.52	0.052	3.0
	S6R06GB-S12 S6R06GB-S12CE	SRB01 SRB01CE	4	6	1 $\phi$ 220	60	30min.	90-1700	0.60	0.060	0.40	0.040	0.52	0.052	0.8
	S6R06GC-S12 S6R06GC-S12CE	SRC01 SRC01CE	4	6	1 $\phi$ 100	50 60	30min.	90-1400 90-1700	0.55	0.055	0.35	0.035	0.45	0.045	3.0
	S6R06GD-S12 S6R06GD-S12CE	SRD01 SRD01CE	4	6	1 $\phi$ 200	50 60	30min.	90-1400 90-1700	0.55	0.055	0.35	0.035	0.45	0.045	0.8
	S6R06GX-S12 S6R06GX-S12CE	SRX01 SRX01CE	4	6	1 $\phi$ 220 1 $\phi$ 240	50	30min.	90-1400	0.45 0.50	0.045 0.050	0.32 0.32	0.032 0.032	0.40 0.47	0.040 0.047	0.7

- ❖ 기종명 맨 끝자리에 CE가 명기된 MOTOR MODEL의 인증 관련 내용은 SPG 규격 인증품 현황을 참고하여 주십시오. (CE marked at the end of motor model name indicates that it is thermally protected type which has received CE.)
- ❖ 기종명 맨 끝자리에 CE가 명기된 SR TYPE CONTROLLER MODEL의 인증 관련 내용은 SPG 규격 인증품 현황을 참고하여 주십시오. (SR type controller model with "CE" appeared at the end of motor model name indicates that the product acquired CE MARK certification.)
- ❖ 'L' Type 전용으로 기종명에 표시하지 않습니다. ('L' or 'H' type does not apply to motors under 40W.)

## SPECIFICATION OF SS TYPE SPEED CONTROL MOTORS

SIZE mm sq.	Motor Type	Controller Type	Poles	Output (W)	Voltage (V)	Freq. (Hz)	Duty	Speed Range (rpm)	Permissible Torque				Starting Torque		Cap. ( $\mu$ F)
									at 1200rpm		at 90rpm		(kg-cm)	(N-m)	
60	S6R06GA-S24 S6R06GA-S24CE	SSA01-SRSS SSA03-SRSS	4	6	1 $\phi$ 110	60	30min.	90-1700	0.65	0.065	0.40	0.040	0.52	0.052	3.0
	S6R06GB-S24 S6R06GB-S24CE	SSB01-SRSS SSB03-SRSS	4	6	1 $\phi$ 220	60	30min.	90-1700	0.60	0.060	0.40	0.040	0.52	0.052	0.8
	S6R06GC-S24 S6R06GC-S24CE	SSC01-SRSS SSC03-SRSS	4	6	1 $\phi$ 100	50 60	30min.	90-1400 90-1700	0.55	0.055	0.35	0.035	0.45	0.045	3.0
	S6R06GD-S24 S6R06GD-S24CE	SSD01-SRSS SSD03-SRSS	4	6	1 $\phi$ 200	50 60	30min.	90-1400 90-1700	0.55	0.055	0.35	0.035	0.45	0.045	0.8
	S6R06GX-S24 S6R06GX-S24CE	SSX01-SRSS SSX03-SRSS	4	6	1 $\phi$ 220 1 $\phi$ 240	50	30min.	90-1400	0.45 0.50	0.045 0.050	0.32 0.32	0.032 0.032	0.40 0.47	0.040 0.047	0.7

- ❖ 기종명 맨 끝자리에 CE가 명기된 MOTOR MODEL의 인증 관련 내용은 SPG 규격 인증품 현황을 참고하여 주십시오. (CE marked at the end of motor model name indicates that it is thermally protected type which has received CE.)
- ❖ 'L' Type 전용으로 기종명에 표시하지 않습니다. ('L' or 'H' type does not apply to motors under 40W.)

### 50Hz

MODEL	GEAR RATIO	3	3.6	5	6	7.5	9	10	12.5	15	18	20	25	30	36	40	50	60	75	90	100	120	150	180	200	250
	rpm	500	416	300	250	200	166	150	120	100	83	75	60	50	41	37	30	25	20	16	15	12	10	8	7.5	6
S6DA□B	kg-cm	1.3	1.5	2.1	2.6	3.2	3.9	4.3	5.4	6.4	7.7	7.7	9.7	11.6	13.9	15.5	17.5	21.0	26.2	30.0	30.0	30.0	30.0	30.0	30.0	30.0
	Nm	0.127	0.147	0.206	0.255	0.314	0.382	0.421	0.529	0.627	0.755	0.755	0.951	1.137	1.362	1.519	1.715	2.058	2.568	2.942	2.942	2.942	2.942	2.942	2.942	2.942

### 60Hz

MODEL	GEAR RATIO	3	3.6	5	6	7.5	9	10	12.5	15	18	20	25	30	36	40	50	60	75	90	100	120	150	180	200	250
	rpm	600	500	360	300	240	200	180	144	120	100	90	72	60	50	45	36	30	24	20	18	15	12	10	9	7.2
S6DA□B	kg-cm	1.0	1.3	1.7	2.1	2.6	3.1	3.5	4.4	5.2	6.3	6.3	7.8	9.4	11.3	12.6	14.2	17.0	21.3	25.5	28.4	30.0	30.0	30.0	30.0	30.0
	Nm	0.098	0.127	0.167	0.206	0.255	0.304	0.343	0.431	0.510	0.617	0.617	0.764	0.921	1.107	1.235	1.392	1.666	2.087	2.499	2.783	2.942	2.942	2.942	2.942	2.942

- ❖ GEAR HEAD 품명 중 □은 감속비를 표시합니다. (The code in □ of gearhead model is for gear ratio.)
- ❖ GEAR HEAD와 조합한 경우의 허용 TORQUE입니다. (It is the permissible torque of the assembled motor and gearhead.)
- ❖ 감속비 1/10의 중간 GEAR HEAD를 접속한 경우의 허용 TORQUE는 30kg-cm입니다. (The permissible torque of the motor and inter-decimal gearhead is 30 kg-cm.)
- ❖ 회전방향은 ■색이 MOTOR의 회전방향과 동일방향이고, 기타는 MOTOR 회전방향과 반대방향입니다. (■ color indicates that the output shaft of the geared motor rotates in the same direction as the output shaft of the motor. Others indicate rotation in the opposite direction.)
- ❖ 회전수는 MOTOR의 동기 회전수(50Hz : 1500rpm, 60Hz : 1800rpm)를 기준으로 하여 감속비로 나누어서 계산하였습니다. 실제의 회전수는 부하의 크기에 따라서 표시된 수치보다 2~20% 적습니다. (Rpm is based on synchronous speed (50Hz: 1500rpm, 60Hz: 1800rpm) divided by gear ratio. The actual rotation speed can be 2~20% less than displayed value depending on the load.)
- ❖ 'L' Type 전용으로 기종명에 표시하지 않습니다. ('L' or 'H' type does not apply to motors under 40W.)

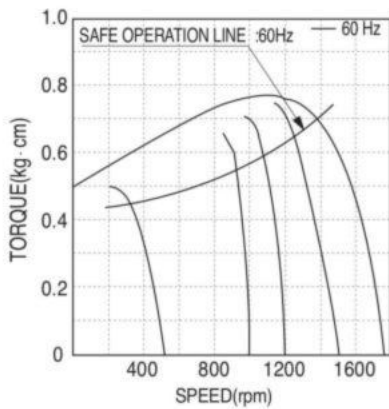

- ▲ S6R06GA-S12 S6R06GA-S24
- S6R06GA-S12CE S6R06GA-S24CE
- S6R06GB-S12 S6R06GB-S24
- S6R06GB-S12CE S6R06GB-S24

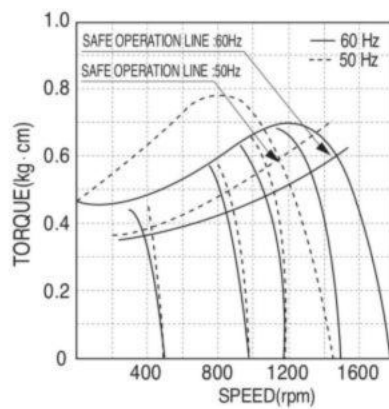

- ▲ S6R06GC-S12 S6R06GC-S24
- S6R06GC-S12CE S6R06GC-S24CE
- S6R06GD-S12 S6R06GD-S24
- S6R06GD-S12CE S6R06GD-S24CE

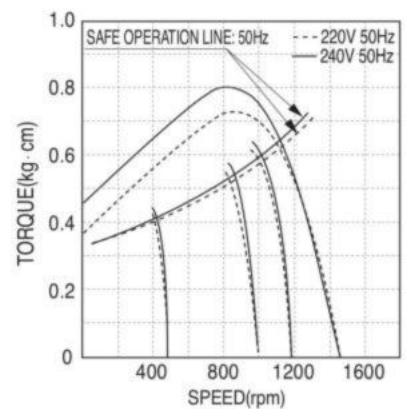

- ▲ S6R06GX-S12 S6R06GX-S24
- S6R06GX-S12CE S6R06GX-S24CE

# DIMENSIONS

## + GEARED MOTOR

= MOTOR MODEL : S6R06G□-S12, S6R06G□-S24  
 = HEAD MODEL □ : S6□A3□~S6□A250□

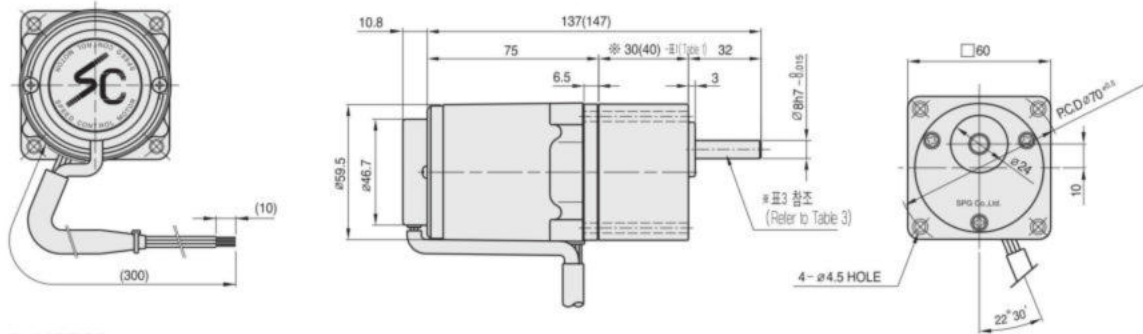

## + MOTOR

= MOTOR MODEL : S6R06□□-S12, S6R06□□-S24

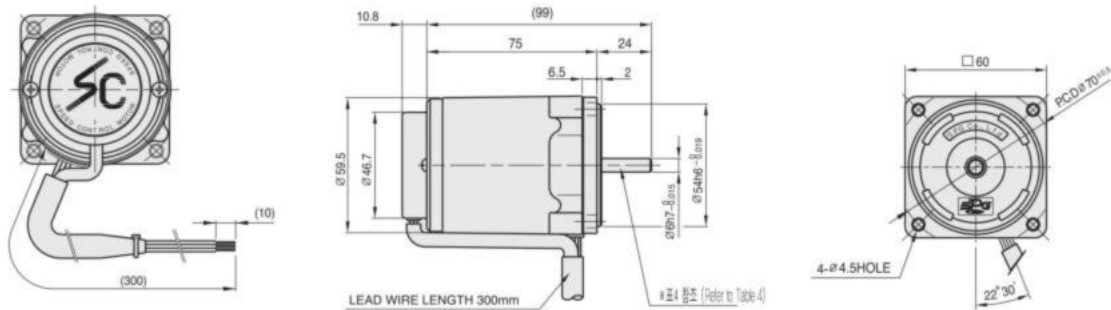

## + INTER-DECIMAL GEAR HEAD

= MODEL : S6GX10B

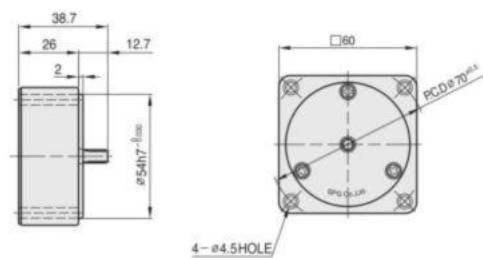

## + KEY SPEC

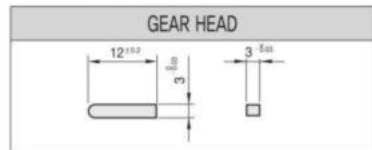

## + ※30(40) - (표1 Table1)

GEAR RATIO	SIZE(mm)
S6□A3□ ~ S6□A18□	30
S6□A20□ ~ S6□A250□	40

## + WEIGHT - (표2 Table2)

PART	WEIGHT(kg)	
MOTOR	0.76	
DECIMAL GEAR HEAD	0.18	
GEAR HEAD	S6□A3□ ~ S6□A18B□	0.24
	S6□A20□ ~ S6□A40□	0.30
	S6□A50□ ~ S6□A250□	0.33

## + GEAR HEAD 출력축 사양 (SPEC for output shaft of gearhead) - (표3 Table3)

MODEL	출력축 구분 (TYPES OF OUTPUT SHAFT)
S6SA3□ ~ S6SA250□	STRAIGHT TYPE 
	D-CUT TYPE 
S6DA3□ ~ S6DA250□	KEY TYPE 

## + MOTOR 출력축 사양 (SPEC for output shaft of motor) - (표4 Table4)

MODEL	출력축 구분 (TYPES OF OUTPUT SHAFT)
S6R06G□-S12 S6R06G□-S24	GEAR TYPE 
	STRAIGHT TYPE 
S6R06D□-12 S6R06D□-12	D-CUT TYPE 