



PCH Series 3-Phase

0.4kW

■ SPECIFICATION

■ MOTOR

출력 Output (kW)	기종명 Model Name	극수 Poles	전압 Voltage (V)	주파수 Freq. (Hz)	정격 부하 [Rated Load]			사용 조건 Duty	보호 등급 Degrees of protection	절연 등급 Insulation Classification	냉각 방식 Protective Cooling System
					전류 Current (A)	모터속도 Speed (r/min)	효율 Efficiency (%)				
0.4	PCH□-□-M□040R4□	4	220/380	60	2.00/1.20	1730	74.1	CONT.	IP55 (IP40)	F	Totally Enclosed Fan-Cooled
			200	50	2.20	1450	74.2				
	PCH□-□-M□040W6□	4	200/220	60	1.80/1.90	1735/1745	76.4/75.7				
			380/400	50	1.10/1.10	1425/1430	75.5/74.1				
	PCH□-□-M□040X6□	4	400/440	60	1.00/1.00	1710/1725	75.4/75.2				

- Brake 부착 Geared Motor는 방수방진 등급이 IP40 비방수형 제품과 IP55 방수형 제품의 2가지 Model 이 있습니다.(The Brake Geared Motor is divided into 2 models: one is a non-water proof product with IP40 while the other is a waterproof product with IP55.)
- IP40 모델과 IP55 모델의 전기적 특성 사양은 동일합니다.(The Models with IP40 and IP55 have the same electric characteristics.)

■ GEARED MOTOR – 50Hz

Frame No.	30											35						
감속비 (Reduction gear ratio)	5	7.5	10	12.5	15	20	25	30	40	50	60	80	100	120	160	★200	★240	
회전 속도 (Rotation speed (r/min))	300	200	150	120	100	75	60	50	37.5	30	25	18.8	15	12.5	9.4	7.5	6.3	
허용 토크 (Allowable torque)	kgf · m	1.10	1.70	2.29	2.85	3.40	4.50	5.60	6.79	8.99	11.3	13.6	17.6	22.1	26.5	32.7	32.7	35.6
	N · m	10.8	16.7	22.5	27.9	33.3	44.1	54.9	66.6	88.2	111	133	173	217	260	321	321	349
허용 (Allowable) O.H.L	kgf	200	225	250	265	280	310	330	340	360	360	360	380	380	380	380	380	380
	N	1960	2205	2450	2597	2744	3038	3234	3332	3528	3528	3528	3724	3724	3724	3724	3724	3724

■ GEARED MOTOR – 60Hz

Frame No.	30											35						
감속비 (Reduction gear ratio)	5	7.5	10	12.5	15	20	25	30	40	50	60	80	100	120	160	★200	★240	
회전 속도 (Rotation speed (r/min))	360	240	180	144	120	90	72	60	45	36	30	22.5	18	15	11.3	9	7.5	
허용 토크 (Allowable torque)	kgf · m	0.92	1.41	1.90	2.35	2.79	3.79	4.70	5.70	7.49	9.39	11.3	14.8	18.4	22.1	27.3	27.3	29.6
	N · m	9.02	13.8	18.6	23	27.4	37.2	46.1	55.9	73.5	92.1	111	145	180	217	268	268	290
허용 (Allowable) O.H.L	kgf	200	225	250	265	280	310	330	340	360	360	360	380	380	380	380	380	380
	N	1960	2205	2450	2597	2744	3038	3234	3332	3528	3528	3528	3724	3724	3724	3724	3724	3724

- Note) • “★” 표시된 감속비의 제품은 Permissible Torque(허용토크)가 제한됩니다.(Permissible Torque is limited for products with a mark “★” of reduction gear ratio)
- Permissible O.H.L (허용 Overhung 하중)의 적용은 출력축 Shaft 인출 길이의 중심부 기준임.(Permissible O.H.L (allowable overhung load) is based on the central part of the outlet length for output shaft)
 - ■ 색 부의 회전방향은 □ 색 부의 방향과 반대방향 입니다.(Rotation direction of color ■ is opposite of other color □)
 - Self Locking (자립 잠김)은 작동하지 않습니다.(Self Locking is unavailable.)

기종명 (Model Name) Coding
▶ 73Page

출력축 사양 (Specification for output shaft)
▶ 100Page

기술자료 (Technological Data)
▶ 101Page

■ PCH TYPE DIMENSIONS [Lead Box Type]

UNIT = mm

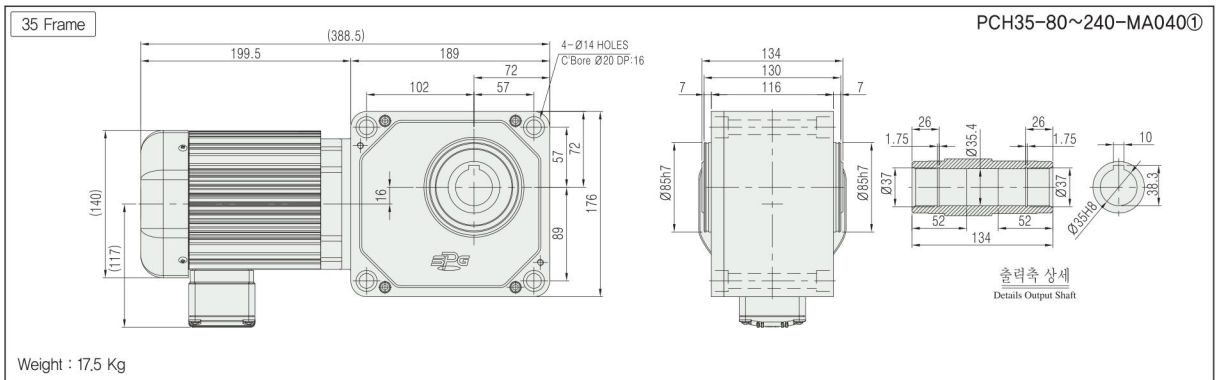
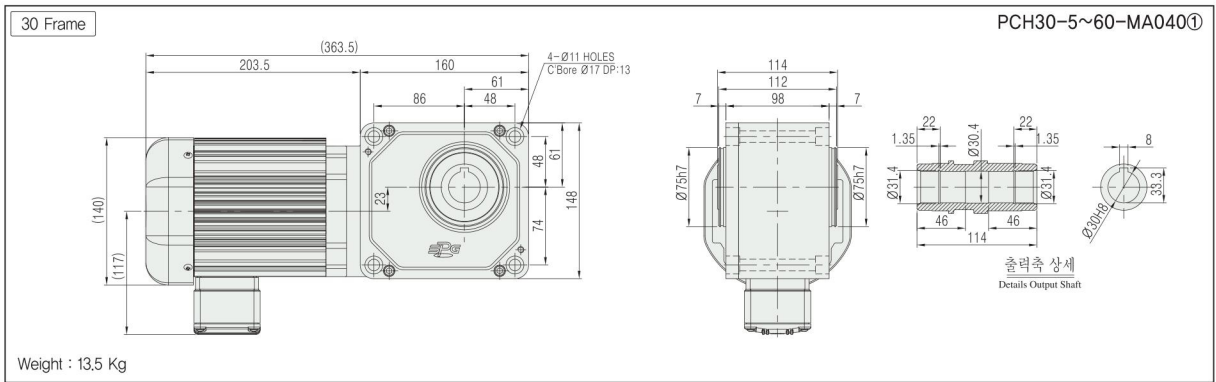

■ PCH TYPE DIMENSIONS [Terminal Box Type]

- Note) • IP40 모델과 IP55 모델의 외관 치수는 동일합니다.(Dimensions for IP40 model and IP55 model are the same.)
 • BRAKE 부착 모델은 Terminal Box Type 을 기본으로 적용하고 있으며, Lead Box Type 은 적용하고 있지 않습니다.(The brake-attached model is applied to the Terminal Box Type for basic features, but does not apply to the lead wire box type.)
 • Dimensions 내의 () 치수 및 중량은 Brake 부착 모델의 사양입니다.(() dimension and weight in dimensions is for brake attached model specification)

UNIT = mm

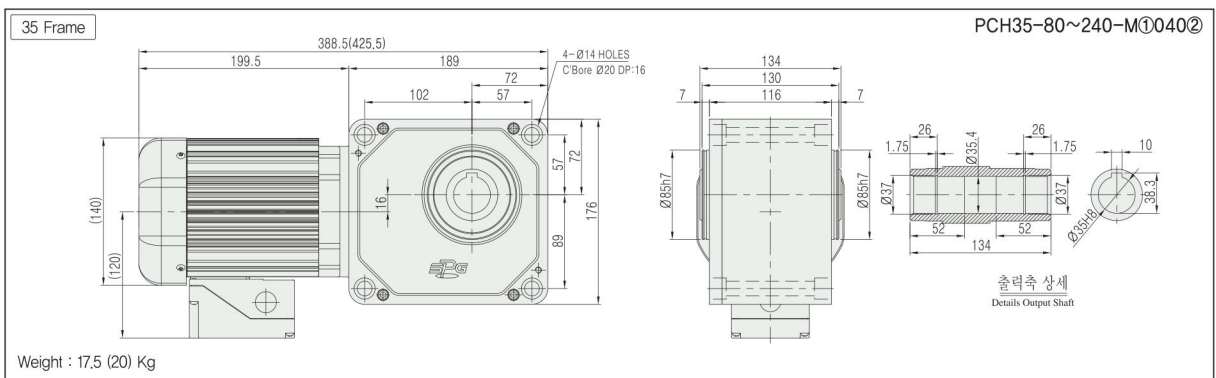
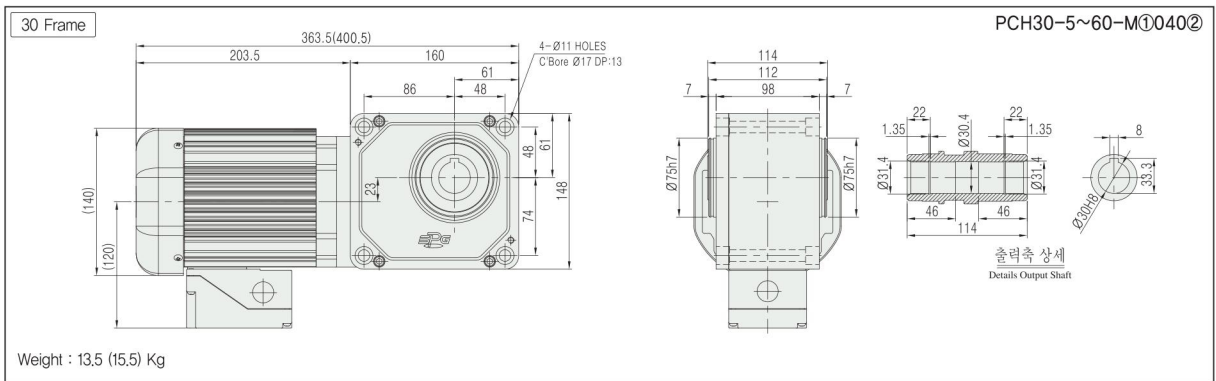

- 기종명 구분(Model type) ① : 모터옵션(Motor option) (B, C, D)
 ② : 전원(Power) (Voltage & Frequency)

기종명 (Model Name) Coding
 ▶ 73Page

출력축 사양 (Specification for output shaft)
 ▶ 100Page

기술자료 (Technological Data)
 ▶ 101Page